



XDI-F6 Hazardous Area Gas Detector

Specification Sheet Ref C959

JUNCTION BOX

Type - XDI

Flame proof

Classification Certificate

ATEX – EExd IIC T6 T85°C II2GD
Certificate No. FTZU-06ATEX0296X

Lid/Base

Thread type with lock screw - 2mm

Ingress Protection

IP66

Material

Body & Cover aluminium alloy
Option – stainless steel

Finish

Standard – chemically resistant epoxy paint
Option – marine grade finish

Entries

Two entry
20mm 1.5 pitch standard
alternative 25mm – ¼ NPT

Mounting Detail

Two M5 (126mm CRS)

Weight

XDI-1.2Kg XDI-win-1.5kg

Approx. Dimensions

XDI-115mm W x 108mm H XDI-win -115mm W x 130mm H



DETECTOR HEAD

Type – F6

Data Sheet

Ref C994

Classification Certificate

ATEX/IECEX ExdII T6 Gb
Sira-08ATEX 1313X
IECEX SIR 08.0123X

Ingress Protection

IP63 + weather shield IP65

Sensor Inserts

Electrochemical
Pellistor catalytic

Mounting Thread

20mm 1.5mm Pitch

Material

Stainless Steel 316 S16

Accessories

Universal Fitting (weather cone/test gas fitting)	Pt No. 003-060
Collector Cone & Universal Fitting	Pt No. 003-062
Flow Block	Pt No. 003-063

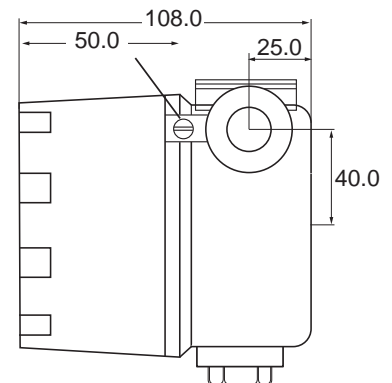
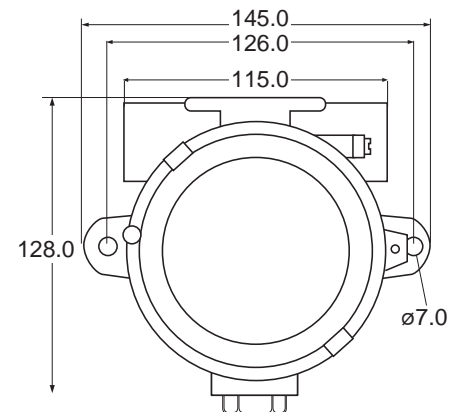

SEAGULL SAFETY LTD

45 Chestnut Avenue, Wokingham RG41 3HW
Berkshire, England
Tel: (44) 118 978 5986
Fax: (44) 118 977 5261
info@seagullssafety.com

SEAGULL SAFETY (SINGAPORE) PTE LTD

1 Genting Link, #07-06, Perfect Industrial Building
Singapore 349518
Tel: (65) 6747 9646
Fax: (65) 6744 4028
info@seagullssafety.com

