



S888-ExFGPP 16/64 Explosion Proof Fire and Gas Controller



- Fire & Gas Detection
- Offshore Service Module Pressurisation Control
- Site Perimeter Gas Detection

FEATURES

- Up To 64 Nos. Addressable Gas Detectors
- Up To 16 Nos. 4-20mA Gas Detectors
- Up To 12 Nos. 4-20mA Gas Detectors and 4 Nos. Fire Detection Inputs
- Relays For Voltage Free Contact Outputs
- Full System Status Shown On 4 Line Lcd Display

Control of pressurised offshore service module To DNVGL Standard 2.7-2, Feb 2016.

INPUTS:

- 2 X Pressure Detection
- 2 X Fire Detection
- 3 X Gas Detection

OUTPUTS:

- 6 X V/F contacts to offshore installation (system status)
- 4 X control signals to module (required system logic and timing provided in control software)

TECHNICAL SPECIFICATION

INPUTS

- 1-64 addressable – CANbus
- 1-16 direct 4-20mA inputs

MEASUREMENTS

- Combustible Gas - L.E.L., % vol
- Toxic Gas - ppm, % vol
- Oxygen - % vol - Depletion /Enrichment
- Refrigerant - ppm
- Any 4-20mA transmitter

DISPLAY

- Dot matrix LCD 4 line 40 character - indicating sensor location, gas type, alarm status, system fault, sensor line fault, sensor fault, inhibit, real time clock, event memory

OUTPUTS

- Up to 2 x 8 way Relay Cards
- Event log
- 2 x Modbus - RS485
- 2 x CANbus

AUDIBLE ALARM

- Alarm/Fault - with mute

POWER

- 110/230 VAC or 24 VDC

MISCELLANEOUS

- Enclosure cable entry - bottom, top
- Reset and Mute push buttons on front panel
- Purge Start and Fan Stop push buttons on front panel for DNVGL 2.7-2 version
- Repeater panel option
- Password protection - user mode/engineers mode
- LCD and LED dimming

ENVIRONMENT

- IP rating: IP66
- Operating temperature: -20° C to +60° C

DIMENSIONS

- 460 (W) x 340 (H) x 300 (D) mm

CERTIFICATION

- ATEX CERTIFICATION: IMQ 11 ATEX 031X
- IECEx CERTIFICATION: IECEx IMQ 14.0010X
- Ⓜ II 2G Ex db IIB + H2 T6 Gb
- Ⓜ II 2D Ex tb IIIC T85°C Db
- IP66, Ta -20°C to + 60°C



SEAGULL SAFETY

S888-ExFGPP 16/64 Explosion Proof Fire and Gas Controller

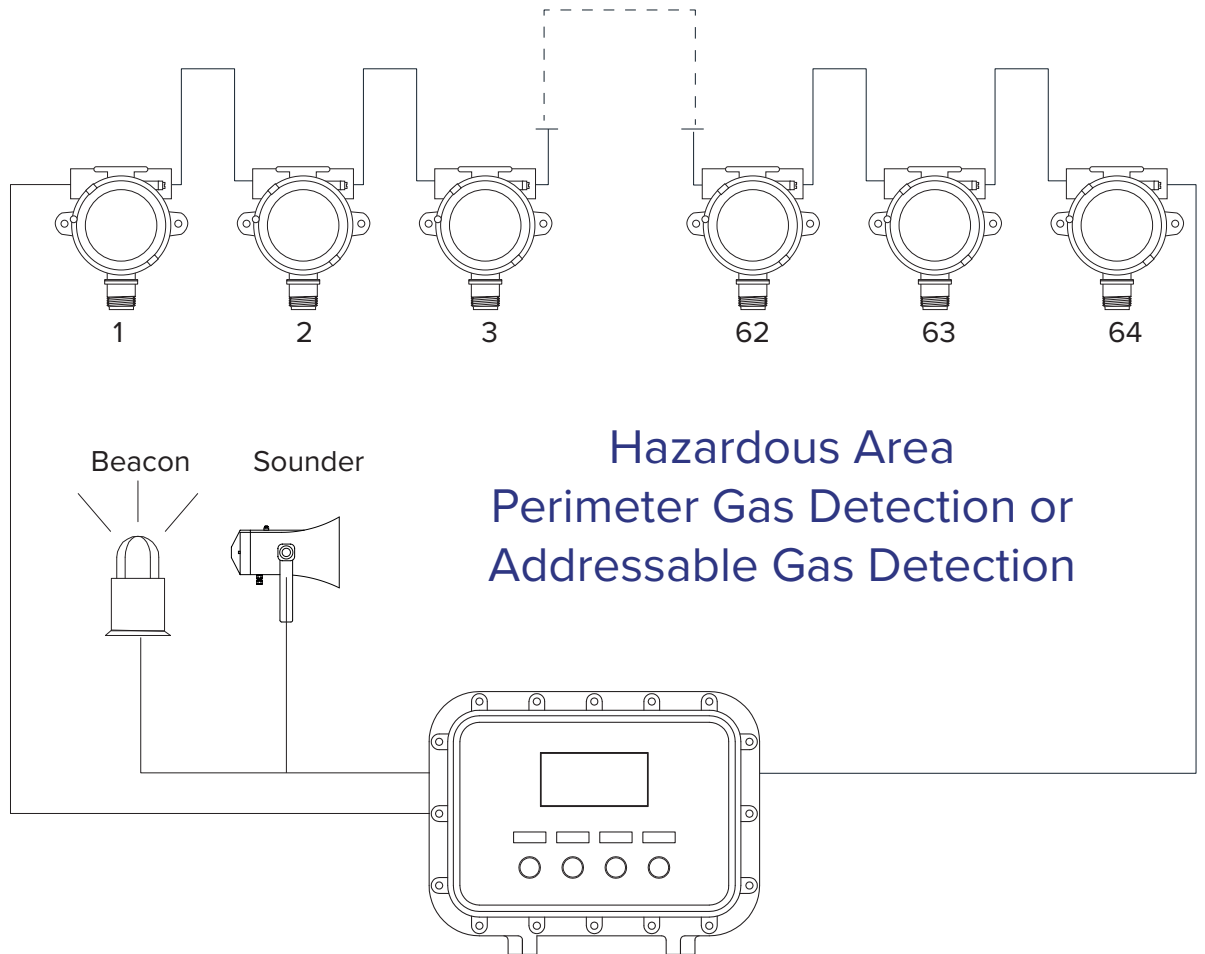
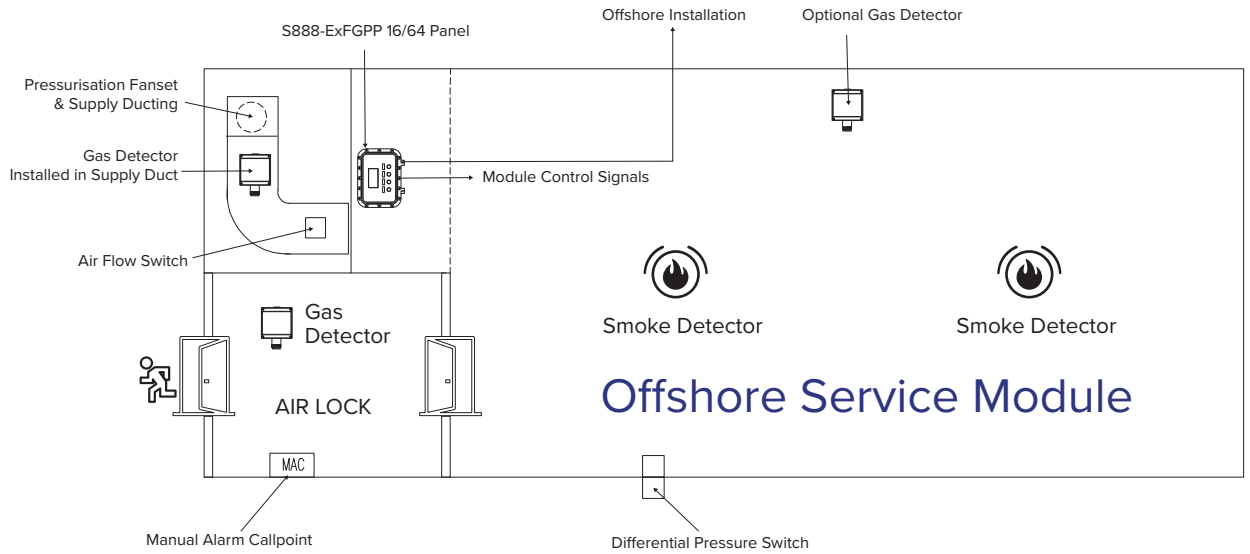

Seagull Safety Ltd
45 Chestnut Avenue,
Wokingham RG41 3HW
Berkshire, England
Tel: (44) 1753 474 112
Fax: (44) 118 977 5261

Seagull Safety (Singapore) Pte Ltd
1 Genting Link,
#07-06 Perfect One
Singapore 349518
Tel: (65) 6747 9646
Fax: (65) 6744 4028

Email: info@seagullssafety.com

www.seagullssafety.com



ISO 9001:2015 CERT NO.: 621945